

## CLASS 900 ~ 2500 GLOBE VALVE – OS&Y, WB TYPE

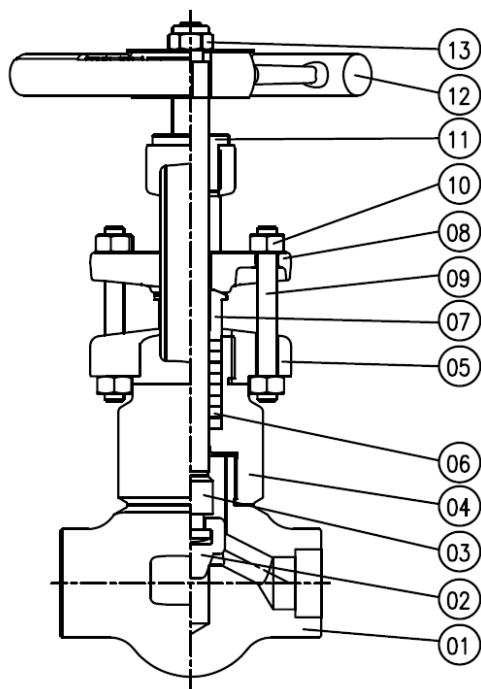

### SPECIFICATIONS

- 1) Valve Size: 1/2" ~ 2"
- 2) Applicable Rating: ASME 1500# ~2500#
- 3) Temperature: Up to 500°C
- 4) Code & Standard: API, BS, ASME, ASTM  
Designed by ASME B16.11 / 16.34 / 16.5,  
API 602
- 5) Constructions
  - \* End Connection: Socket-Welded or Flanged Type
  - \* OS & Y, WB (=Welded Bonnet) Type
  - \* Full Bore / Reduce Bore
  - \* Rising Stem / Rising Hand wheel
  - \* Manual or Motor Operated  
(Pneumatic, Electric, or Hydraulic)

SHELL & SEAT LEAKAGE TEST PRESSURE(A105)			
CLASS	SHELL (kgf/cm <sup>2</sup> )	SEAT (kgf/cm <sup>2</sup> )	
	WATER	AIR	WATER
900#	236	-	172
1500#	393		287
2500#	653		478

### STANDARD COMPONENT MATERIALS

NO	Part Name	MATERIAL(BODY/TRIM)				
		A105/F6a	LF2/304	F11/F6a	F304(L)/304(L)	F316(L)/316(L)
01	BODY	A105	LF2	F11	F304(L)	F316(L)
02	DISC	A276-410	A276-304	A276-410	A276-304(L)	A276-316(L)
03	STEM	A276-410	A276-304	A276-410	A276-304(L)	A276-304(L)
04	BONNET	A105	LF2	F11	F304(L)	F304(L)
05	YOKE	A105	A105	A105	A351-CF8M	A351-CF8M
06	GLAND PACKING	Graphite	Graphite	Graphite	Graphite	Graphite
07	GLAND	A276-410	A276-410	A276-410	A276-316	A276-316
08	GLAND FLANGE	A105	A105	A105	F316	F316
09	GLAND BOLT	A193-B7	A193-B7	A193-B7	A193-B8	A193-B8
10	GLAND BOLT NUT	A194-2H	A194-2H	A194-2H	A194-8	A194-8
11	SLEEVE	A276-410	A276-410	A276-410	A276-410	A276-410
12	HAND WHEEL	A47	A47	A47	A47	A47
13	WHEEL NUT	A108-1020	A108-1020	A108-1020	A108-1020	A108-1020

## CLASS 900 ~ 2500 GLOBE VALVE – OS&Y, WB TYPE

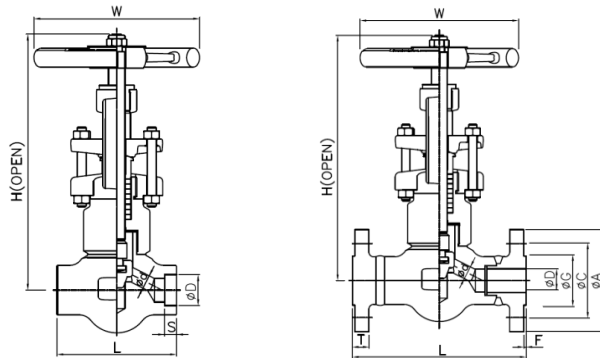

### Connection ends conform to:

- 1) Socket welded ends conform to ASME B16.11
- 2) Screw ends conform to ASME B1.20.1
- 3) Butt-welded ends conform to ASME B16.25
- 4) Flanged ends conform to ASME B16.5

### - DIMENSION TABLE (Socket Welding End)

CLASS	SIZE	H	W	L	d	ANSI		JIS		WEIGHT (KG)
						D	S	D	S	
#900 #1500	1/2"	234	150	114	10.0	21.8 - 22.2	10	22.2 - 22.5	9.7	5.7
	3/4"	256	150	114	11.0	27.2 - 27.6	13	27.7 - 28.0	12.7	6.2
	1"	283	180	130	15.0	33.9 - 34.3	13	34.5 - 34.8	12.7	8.6
	1-1/4"	328	200	150	20.0	42.7 - 43.1	13	43.2 - 43.5	12.7	13.7
	1-1/2"	328	200	150	28.0	48.8 - 49.2	13	49.1 - 49.4	12.7	13.5
	2"	426	250	190	32.0	61.2 - 61.7	16	61.1 - 61.4	15.9	25.6
#2500	1/2"	267	150	114	10.0	21.8 - 22.2	10	22.2 - 22.5	9.7	6.5
	3/4"	299	180	130	11.0	27.2 - 27.6	13	27.7 - 28.0	12.7	8.9
	1"	354	200	150	15.0	33.9 - 34.3	13	34.5 - 34.8	12.7	14.0
	1-1/4"	399	250	190	20.0	42.7 - 43.1	13	43.2 - 43.5	12.7	26.8
	1-1/2"	399	250	190	28.0	48.8 - 49.2	13	49.1 - 49.4	12.7	26.2
	2"	452	250	260	35.0	61.2 - 61.7	16	61.1 - 61.4	15.9	28.7

### - DIMENSION TABLE (RF FLANGE End)

CLASS	SIZE	H	W	L	d	D	G	C	A	T	F	N x M	WEIGHT (KG)
#900 #1500	1/2"	234	150	216	10.0	15.8	35.1	82.6	121	22.4	6.4	4x22.4	6.7
	3/4"	256	150	229	11.0	20.9	43.0	88.9	130	25.4	6.4	4x22.4	7.2
	1"	283	180	254	15.0	26.7	50.8	102.0	149	28.5	6.4	4x25.4	9.6
	1-1/2"	328	200	305	28.0	40.9	73.2	124.0	178	31.8	6.4	4x28.5	15.5
	2"	426	250	368	32.0	52.6	92.0	165.1	216	38.1	6.4	8x25.4	27.6
#2500	1/2"	267	150	264	10.0	15.8	35.1	88.9	133.0	36.7	6.4	4x22.4	7.7
	3/4"	299	180	273	11.0	20.9	43.0	95.3	139.7	38.2	6.4	4x22.4	11.3
	1"	354	200	308	15.0	26.7	50.8	108.0	158.8	41.4	6.4	4x25.4	17.6
	1-1/2"	399	250	384	28.0	40.9	73.2	146.1	203.2	50.9	6.4	4x31.8	36.7
	2"	452	250	451	35.0	52.6	92.0	171.5	235.0	57.2	6.4	8x28.5	40.7